

LUMINOUS



 Eco Volt Neo

1250

 Sine Wave

24
MONTHS
WARRANTY

LUMINOUS CARE
EXPERT TECHNICAL SUPPORT

Customer Helpline Number :

Toll Free
Helpline : 1800 103 3039

care@luminousindia.com

User Manual

1. INTRODUCTION

1.1. Welcome to the ever-increasing family of satisfied LUMINOUS users. All LUMINOUS products like the one you have just purchased undergo a stringent quality check. This instrument provides clean & reliable power to your home, office and commercial establishments and protects them from blackouts, etc. this product is designed to provide you an efficient performance with only minimal care and maintenance at your end. This manual will facilitate you to not only understand the basic working of the LUMINOUS device but will also facilitate the ease of its maintenance and use.

लूमिनस के सन्तुष्ट तथा निरन्तर बढ़ने वाले परिवार में आप का स्वागत है। लूमिनस के सभी प्रोडक्ट्स की क्वालिटी जाँच बड़ी कुशलता से की जाती है। यह उपकरण होम तथा ऑफिस उपकरणों को स्वच्छ एवं विश्वसनीय पावर प्रदान करता है और उन्हें ब्लैकआउट होने से बचाता है। लूमिनस के प्रोडक्ट्स इस तरह से डिजाइन किये जाते हैं ताकि यह आपको अच्छी परफार्मेंस दें तथा इन की देखभाल कम से कम समय और कम से कम खर्च से हो सके। इस मैन्युअल के द्वारा आप को इस लूमिनस उपकरण के प्रारम्भिक कामकाज को समझने और इसकी देखभाल करने में सहायता मिलेगी।

1.2. Luminous Eco Volt Neo 1250 Sine Wave UPS provides backup power to load (fan, bulb, computer etc.)

लूमिनस इको वोल्ट निओ 1250 साइन वेव यूपीएस बिजली चले जाने के बाद फैन, बल्ब, कम्प्यूटर इत्यादि को बैकअप पावर प्रदान करता है।

1.3. Normally, the device operates on Mains, supplying power to the load from the utility input. The battery charger uses Mains power to keep the battery at an optimal level. When the power fails, the device transfers the load to the battery and converts the battery's DC power to AC power. The loads operate normally until the battery is exhausted. The load is automatically transferred back to the utility when the normal Mains get restored.

आमतौर पर उपकरण मेन्स पर काम करते हुए लोड को मेन्स से पावर प्रदान करता है। बैट्री चार्जर बैट्री को एक उचित स्तर पर रखने के लिए मेन्स से पावर लेता है। बिजली चले जाने पर उपकरण बैट्री पर काम करते हुए लोड देता है, जब तक बैट्री क्षमता समाप्त नहीं हो जाती। बिजली वापस आने पर लोड अपने आप बैट्री से मेन्स पर ट्रांसफर हो जाता है।

2. SAFETY GUIDELINES please go through these guidelines before connecting the device.

1. Always connect the device to a 230V, 10A/16A, 3 Pin type Mains socket with earthing. The socket must be connected to appropriately protected branch of the Mains (fuse/circuit breaker). Connection to any other type of socket may result in a shock hazard. Kindly ensure that ELCB/RCCB is not connected at either input or output.

उपकरण सदैव दो पोल तथा तीन तार ग्राउंडिंग मेन्स साकेट के साथ जोड़िये। साकेट को मेन्स की उचित सुरक्षित ब्रॉच (फ्यूज / सर्किट ब्रेकर) के साथ जोड़ना चाहिए। किसी और प्रकार के साकेट से जोड़ने से बिजली का झटका लगने की संभावना रहती है। ELCB/RCCB का प्रयोग इनपुट और आउटपुट में न करें।

2. To Switch off the device output, in an emergency, use the switch on the front panel to switch the device off and disconnect the power cord from the Mains & remove at least one battery connector.

आपातकालीन अवस्था में उपकरण की आउटपुट बन्द करने के लिए सामने वाला बटन बन्द करें। पावर के तार को मेन्स से अलग कर दें। बैट्री का कम से कम एक कनेक्टर अलग कर दें।

3. Foreign particles and water must be avoided for the device. Always ensure that no objects containing a liquid are ever kept near the unit.

बाहरी कोई वस्तु या पानी उपकरण के अन्दर नहीं जाना चाहिए। इस बात को ध्यान रखना चाहिए कि गीला या तरल पदार्थ उपकरण के पास नहीं रखना चाहिए।

4. Avoid Installing the device in an excessively humid place or where there is water. Care must be taken to ensure that the device is kept away from heat emitting appliances such as a heater, blower, oven etc. The unit must also be placed in a manner that it avoids exposure to direct sunlight. The place of installation should be well-ventilated and easily accessible for servicing.

उपकरण ऐसे स्थान पर न रखें जहाँ पानी हो या अत्यधिक नमी हो। इस बात का विशेष ध्यान रखा जाए कि उपकरण को उन उपकरणों से दूर रखा जाए जिससे गर्म ताप निकलती है, जैसे हीटर, ब्लोअर और ओवन इत्यादि। उपकरण को ऐसे स्थान पर नहीं लगाना चाहिए जहाँ सीधी धूप आती हो। उपकरण रखने की जगह हवादार और सर्विसिंग के लिए सरलता से पहुँचने योग्य होनी चाहिए।

5. Don't allow any spark near battery. Be sure not to come in contact with battery acid by any means.

बैट्री के निकट कोई चिंगारी न आने दें। बैट्री के तेजाब से किसी भी तरह के सम्पर्क से बचे।

6. Place the battery compartment as near as possible to the device.

बैट्री को उपकरण के नजदीक ही लगाएँ।

7. Always switch off the device and disconnect mains when disconnecting the battery.

बैट्री को हटाने से पहले मेन्स को अवश्य बंद करें।

8. Do not open the device there are dangerous high voltages inside even when power is off, contact the company service engineer only if it is not working properly.

उपकरण को खोलें ना खोलें और सहायता के लिए सर्विस इंजीनियर की मदद लें।

9. Replace the batteries and the fuse only with same rating and type.

बैट्री और फ्यूज को उसी रेटिंग के और मेक से ही बदलें।

DO'S & DON'TS

Do's

✓ Unplug and switch off the device before touching or cleaning the surfaces.

✓ Unplug the device from the wall outlet during a lightning storm.

Don'ts

✗ Don't block the side ventilation slots by cloth or other material it may result in fire hazard.

✗ Don't place the device near radiation or heat source.

✗ Don't install the device near kitchen sink, laundry, wash bowl, bath tub.

Do's related to battery

- ✓ Wear safety gloves and goggles.
- ✓ Use battery grade water only for battery refilling.
- ✓ Install battery in proper ventilated area.
- ✓ Apply petroleum jelly to terminals of batteries.
- ✓ Place battery horizontally & handle with care.
- ✓ Keep out of reach of children.
- ✓ Connect correct polarity of wires from device with battery.

Don'ts related to battery

- ✗ Don't add impure or mineral water in battery.
- ✗ Don't add acid to the battery as it can cause damage.
- ✗ Don't keep near a moisture area or in direct sunlight.
- ✗ Don't keep the cell caps loose or open.
- ✗ Don't increase the length of battery wire.
- ✗ Don't place the battery at height.
- ✗ Never short the terminals of the battery.
- ✗ Don't over fill the battery cells.
- ✗ Keep away flammable things from the battery.
- ✗ Don't dispose of batteries in fire.
- ✗ Don't open or mutilate batteries.
- ✗ Don't keep tools or metal parts on top of batteries.

3. PHYSICAL DESCRIPTION:

3.1 Front Panel: It has display indicators & ON-OFF Switch

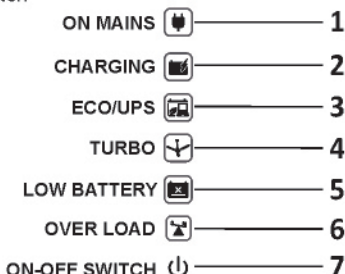

1.ON MAINS : Glows when the commercial Mains is available within normal limits (approx. 100-285V) as input to the unit in unregulated UPS mode and (approx. 180-260V) as input to the unit in regulated UPS mode.

यह चमकता है जब कॉमर्शियल मेन्स इनपुट लगभग (approx. 100-285V) अनरेगुलेटेड यूपीएस मोड में मिलती है और (approx. 180-260V) इनपुट रेगुलेटेड यूपीएस मोड में मिलती है।

2. CHARGING : It indicates battery charging status and shall be ON/OFF as per the charge status of the battery. Charging indication turns OFF when the battery charging is about to be completed.

बैटरी के चार्ज की अवस्था की जांच करता है। इसका ऑन/ऑफ होना बैटरी के चार्ज की अवस्था पर निर्भर करता है। चार्जिंग इन्डिकेशन बंद हो जाता है जब बैटरी की चार्जिंग पूरी होने लगती है।

3. MODE SELECTION :

a) ECO Mode : Glows when the ECO/UPS switch at back-panel is selected as ECO.

यह तब चमकती है जब बैक पैनल में लगा स्विच ऑन हो और इको/ यूपीएस मोड इको में सेलेक्टिड हो।

b) UPS Mode: Glows when the ECO/UPS switch at back-panel is selected as UPS.

यह तब चमकती है जब बैक पैनल में लगा स्विच ऑन हो और इको/ यूपीएस मोड यूपीएस में सेलेक्टिड हो।

4. TURBO : Glows when the mode is selected as Turbo through ON/OFF switch.

फ्रंट ऑन/ऑफ स्विच की सहायता से यह तब चमकती है जब मोड टर्बो में सेलेक्टिड हो।

5. LOW BATTERY : Glows when device trips due to battery energy getting exhausted.

बैट्री की क्षमता खत्म हो जाने के कारण जब उपकरण ट्रिप हो जाता है, तब यह चमकता है।

6. OVER LOAD: Glows when the device is overloaded in battery mode and it trips.

चमकता है जब उपकरण बैटरी मोड पर हो और उस पर क्षमता से अधिक लोड हो, साथ ही बन्द हो जाता है।

7. POWER / RESET SWITCH / MODE SELECTION SWITCH :

7.1 POWER / RESET SWITCH : This switch indicates whether UPS is ON or OFF. If the switch is OFF the UPS will not work in the event of Mains failure, however the charging will continue if Mains is in normal limit.

यह स्विच संकेत करता है कि यूपीएस चालू है या बंद है। यदि स्विच बंद है तो यूपीएस मेन्स ना होने के कारण काम नहीं करेगा। हालांकि मेन्स सामान्य सीमा में है तो चार्जिंग जारी रहेगी।

7.2 MODE SELECTION FROM FRONT SWITCH :

This is used for selection of Normal/Turbo mode. Press front switch & hold up to acknowledge the single beep to set the Normal/Turbo mode. Default mode is Normal mode.

यह स्विच नॉर्मल / टर्बो मोड को इस्तेमाल करने में प्रयोग होता है। नॉर्मल / टर्बो मोड को इस्तेमाल करने के लिए फ्रंट स्विच को बीप की आवाज आने तक दबाए रखें। डिफाल्ट मोड नॉर्मल मोड में होता है।

3.2 THE BACK PANEL

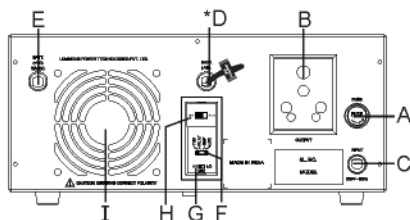

A) MAINS INPUT FUSE : This is connected at the input of device & will disconnect to save the product in case of short-circuit or overload in mains mode.

यह उपकरण के इनपुट पर जुड़ा होता है तथा शॉर्ट-सर्किट या मेन्स मोड में ओवरलोड होने पर प्रोडक्ट को बचाने के लिए अलग कर देगा।

Caution : In case this fuse blows, disconnect the Mains prior to replacing the fuse to avoid electrical shock.

Connect the Mains again after the fuse replacement with a new fuse.

सावधानियाँ : अगर चार्जर फ्यूज खराब हो जाता है तो फ्यूज खराब बदलने से पहले उपकरण का मेन्स (शॉक लगने से बचने के लिए) बन्द कर दें और नया फ्यूज लगाने के बाद दोबारा मेन्स चालू कर दें।

Note: Device should be connected with 25A Class C MCB at building distribution wiring for 1250 model.

नोट: 1250 मॉडल के लिए 25A क्लास सी एमसीबी को बिल्डिंग डिस्ट्रीब्यूशन वायरिंग से जुड़ा होना चाहिए।

B) OUTPUT SOCKET : This socket is provided for connecting the output of the device to the load.

यह साकेट लोड को उपकरण के आउटपुट से जोड़ने के लिए होता है।

C) MAINS LEAD : This is used to connect input AC supply (the commercial supply) to the device.

इसका प्रयोग मेन्स सप्लाई उपकरण से जोड़ने के लिए होता है।

D) NEGATIVE BATTERY LEAD: The negative end of the battery is connected to this lead.

बैटरी का नेगेटिव सिरा इस लीड से जोड़ने के लिए होता है।

***JUNCTION BOX:** This is the battery path fuse & a part of the battery negative wire. Will be replaceable in case of fuse blown due to the reverse connection of the battery or for any other reason.

यह बैटरी पथ फ्यूज है जो बैटरी नेगेटिव तार का एक हिस्सा है। बैटरी के रिवर्स कनेक्शन या किसी अन्य कारण से फ्यूज खराब हो जाता है तब फ्यूज को बदलें।

E) POSITIVE BATTERY LEAD : The positive end of the battery is connected to this lead.

बैटरी का पॉजिटिव सिरा इस लीड से जोड़ने के लिए होता है।

F) BATTERY TYPE SELECTION : This switch should be selected as per battery type.

इस स्विच को बैटरी प्रकार के प्रति चयन किया जाना चाहिए।

Battery Type	Switch Selection
Tubular	TU
Flat Plate	FP
SMF / VRLA	SM
Local / Un-branded	LC

G) BATTERY CHARGING SELECTION : This switch should be selected as per connected battery capacity.

Please refer the below table for selecting the switch position.

बैटरी की क्षमता के अनुसार इस स्विच का चयन किया जाना चाहिए। स्विच की स्थिति के चयन के लिए नीचे दी गई तालिका देखें।

1250	Charging Current Selection Jumper
80Ah to 200Ah	
Battery Capacity	
80Ah to 120Ah	L
120Ah to 150Ah	M
165Ah to 200Ah	H

H) SWITCH (MODE SELECTION)

Regulated UPS Mode (REG) : Normally Switch should be kept in this mode while computer has to be run as this will ensure regulated voltage input of 180V to 260V which is suitable for most of the computers. If the input voltage goes beyond this limit, UPS will run on battery and will restore its operation in Mains mode on restoration of normal Mains.

रेगुलेटेड यूपीएस मोड : सामान्यतः स्विच को इस अवस्था में रखना चाहिए जब कम्प्यूटर चलाना हो, क्योंकि यह ज्यादातर कम्प्यूटरों को 180V से 260V नियमित इनपुट वोल्टेज सुनिश्चित करता है। यदि इस दौरान इनपुट वोल्टेज 180V से 260V से कम या ज्यादा हो जाएगी तो यूपीएस बैटरी मोड पर चलना शुरू कर देगा और जैसे ही मेन्स नॉर्मल हो जाएगी यह मेन्स मोड में वापिस आ जाएगा।

Unregulated ECO Mode (UNREG) : This mode can be used in case of computers having in-built regulation mechanism, or externally connected automatic voltage regulator to take care of wide input voltage fluctuation of 100V to 285V.

अनरेगुलेटेड इको मोड : यदि कम्प्यूटर में अन्तर्निर्मित रेगुलेशन मैकानिज्म (अपने आप वोल्टेज कंट्रॉल सिस्टम) उपस्थित है या बाहरी ऑटोमैटिक वोल्टेज रेगुलेटर से जुड़ा है तो इस मोड पर कम्प्यूटर चलाया जा सकता है। यह वोल्टेज-फ्लक्चुएशन (100-285 वोल्ट) तक काम करेगा।

I). FAN : The assembly for fan.

पंखे के लिए असेम्बली।

4. UNPACKING & PLACEMENT

1. Unpacking: On receiving the device, inspect for any transit damage. The packaging can be saved for future use.

उपकरण को लेते समय इस बात को सुनिश्चित कर ले कि उपकरण क्षतिग्रस्त तो नहीं है। पैकिंग को भविष्य में उपयोग के लिए संभाल के रखें।

2. Placement: Device shall be kept at a place which is protected from dust, water, temperature and humidity.

उपकरण को ऐसे जगह पर लगाएँ जो धूल, पानी, ताप और आर्द्रता से सुरक्षित हो।

5. INSTALLATION DIAGRAMS

1). BATTERY INSTALLATION

CAUTION: Battery polarity must be checked before connections. Wrong polarity connection with device will causes Reverse Protection Fuse Blown and may lead to Fire Hazards.

Installation shall be done by qualified technician.

- Take precautions while connecting the battery cable to the battery post, avoid short circuit by spanner etc.
- Battery terminals and thimble etc., should be cleaned and properly fastened otherwise it may give false indications of battery charged and low battery trips.

2). BATTERY CONNECTIONS WITH DEVICE

a) Eco Volt Neo 1250

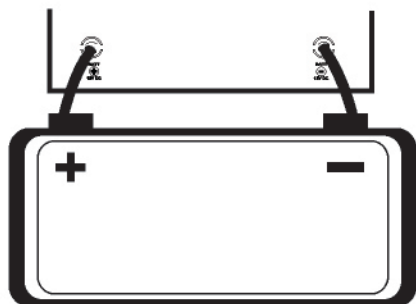

6. CONNECTION DIAGRAM WITH MAINS

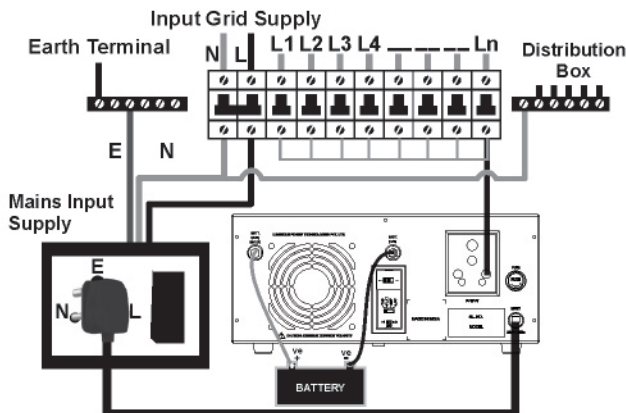

Load Connection (should not be greater than system capacity)

7. STEPS FOR INSTALLATION:

- To be done by a competent & knowledgeable person.
- Switch OFF the supply to the distribution point to which the device is to be connected.
- Check the building wiring. Improper wiring will not prevent the device from operating but will limit its protection capability.
- Improper building wiring could result in equipment damage that is not covered in warranty.
- Connect the battery/batteries to device as per its correct polarity.
- Keep the front switch of device on OFF position.
- Switch ON the front switch & measures the output voltage on output socket, it should be as per specification & switch off the device.
- Connect the Load wire to the line point (right hole) of Output plug & insert the output plug into socket located on the rear panel of device.
- Switch ON the front Switch of the device.
- Gradually put the load on device.
- Connect input plug to commercial mains socket in correct polarity.

लगाने के तरीके:

- इंस्टालेशन बहा इंजीनियर द्वारा ही करा जाना चाहिए।
- उपकरण की मेन्स सप्लाइ को बंद कर दें।
- वायरिंग की सही से जांच कर लें, गलत वायरिंग उपकरण की कार्यक्षमता और वारंटी पर असर डाल सकती है।
- बैट्री को उपकरण के साथ करैक्ट पोलैरिटी में जोड़ें।
- उपकरण को स्विच ऑफ की स्थिति में ही एक्से बैट्री कनेक्ट करने के बाद स्विच ऑन करें और आउटपुट वोल्टेज माप लें, यदि यह निर्देशित रेंज में है तो स्विच ऑफ कर दें।
- आउटपुट प्लग को आउटपुट सॉकेट में डालें और लोड ऑन करें।
- मेन्स इनपुट के प्लग को सही पोलैरिटी में इनपुट पाइंट में कनेक्ट करें।

8. TROUBLESHOOTING

PROBLEM	POSSIBLE CAUSE(S)	ACTION RECOMMENDED
A. The Mains supply is normal but... a) The ON Mains indicator is off. The UPS is either working on battery (UPS/ECO + Mains Fuse fail indicator is glowing) or battery has exhausted (LOW BATT. is glowing).	<ul style="list-style-type: none">• Line cord plug is loose.• Dead wall socket.• Mains input voltage too low or too high.• Mains fuse is open.	<ul style="list-style-type: none">• Fit the line cord plug properly.• Check the socket with any lamp etc.• Wait for Mains to normalize.• Replace the fuse.
B. In the battery mode all indicators are off but the LOW BATT. indicator glows.	<ul style="list-style-type: none">• The battery may have got discharged from recent use.	<ul style="list-style-type: none">• Recharge the battery after Mains restoration.
C. (a) In the battery mode all indicators are off but the UPS OVERLOAD indication is constant. (b) In the battery mode all indicators are off but OVERLOAD indication is blinking.	<ul style="list-style-type: none">• The UPS has tripped due to overload condition.• The UPS is tripped due to short circuit in UPS mode.	<ul style="list-style-type: none">• Reduce the loads and turn the reset switch (on the front panel) on/off.• Switch off all loads and then turn on load one by one and if 'OVER LOAD' blinking indication takes place again, call for authorised technician.

9. WARRANTY

LUMINOUS POWER TECHNOLOGIES PVT. LTD. warrants its UPS to be free from defects in materials and workmanship. This obligation is limited to servicing any instrument or part returned to the authorised service centre for that purpose and to making good any parts thereof which shall, within the warranty period, be returned to the Company or authorised service centre under a written intimation and which to the Company's satisfaction be found defective. The Company reserves the right to decide as to whether the repair work should be carried out in the Company's service centre or at site or at any other place. The freight incurred for to and fro dispatch of the defective material will have to be borne by the customer and the transit risk for the material will rest with the purchaser.

The warranty covers all parts and will last for a period of 24 months from the date of sale to consumer / dispatch of the instrument if used within its specifications. The warranty for the replaced components will lapse along with that of the main instrument. **LUMINOUS POWER TECHNOLOGIES PVT. LTD.** reserves the right to make changes in design and specifications without notice and without any obligation to install such changes on units previously supplied.

In no event will the Company, that is **LUMINOUS POWER TECHNOLOGIES PVT. LTD.**, its Distributors and/ or Dealers be liable for personal injury, damages to property, consequential or incidental damages or for any expenses incurred by the buyer or user, due to use or sale of UPSs sold by **LUMINOUS POWER TECHNOLOGIES PVT. LTD.** directly or through its authorised Distributors/ Dealers or any third party under any circumstances, whether based on tort or breach of contract claims or on any other basis, to the extent these damages may be disclaimed by law. Except as expressly provided herein, the Company makes no warranties, and disclaims all warranties, representations and guarantees (whether expressly, implied or statutory), including, but not limited to, any implied merchantability or fitness for a particular purpose.

Until superseded otherwise or in contractual form, this warranty is made expressly in lieu of all other liabilities and obligations on part of **LUMINOUS POWER TECHNOLOGIES PVT. LTD.** Title to the instrument passes to the buyer upon delivery to the common carrier.

The warranty of your UPS shall become null & void if:

- Our instruments are warranted solely against poor workmanship and use of faulty material resulting in damage that may arise despite normal operation and usage of the appliance, as prescribed in the operating manual. This warranty does not cover any other aspect, including defects arising by reasons of accidents, abuse, misuse, neglect, improper installation (if not undertaken by the company or its representative), fire, flood or other act of God or any other natural calamities. Consequences of any other un-authorised repairs done or carried out will have to be borne by the purchaser.
- The problem of Thermal Circuit Breaker blown will not be included in the warranty of the product. The services given for the same will be a paid service.
- This warranty is not valid if the serial number and/or warranty seal of the Luminous UPS has been deleted, defected or altered.
- Any accessories (like battery, battery trolley, LED/LCD, plastic parts or any house hold goods etc.) connected to the instrument will not be covered under this warranty.
- All disputes for and/ or in connection with the instrument or the warranty in respect thereof shall be subject to the exclusive jurisdiction of courts of Delhi only.

IMPORTANT:

In the event of an instrument requiring servicing at our authorised service center, the following procedure should be adopted.

1. The instrument must be securely packed, preferably in its original packing.
2. The instrument should be despatched on Freight-prepaid basis duly insured.
3. One of our Service/ Sales Executives should be informed of the Goods Receipt No. and date of dispatch along with the name of the carrier.
4. Luminous reserve the right to charge the consignee for any damage incurred during transit.
5. This warranty card should be kept intact as the same will be required along with the original invoice to process the claim.

EQUIPMENT DETAILS

MODEL : Eco Volt Neo Sine Wave	<div style="border: 1px dashed black; width: 100%; height: 100%;"></div>
Eco Volt Neo 1250 <input type="checkbox"/>	
Sr. No. :	

* The actual product/color may vary from that shown in the manual.

10. SPECIFICATIONS

Models		1250
Apparent Power		1100VA
Active Power		924W
Input	UPS mode	
	Rated voltage	230V AC
	Undervoltage Cut Off	180±5V
	Undervoltage Restoration	190±5V
	Overvoltage Cut Off	265±5V
	Overvoltage Restoration	255±5V
	ECO mode	
	Undervoltage Cut Off	85±10V
	Undervoltage Restoration	105±10V
	Overvoltage Cut Off	285±10V
Overvoltage Restoration	275±10V	
Output	Rated voltage (Normal Mode)	(200 - 220)V AC ± 5%
	Rated voltage (Turbo Mode)	(200 - 240)V AC ± 5%
	Voltage (Mains Mode)	Same as input
	Frequency (UPS / ECO Mode)	50 ± 0.5Hz
	Frequency (Mains Mode)	Same as input (45-55 Hz)
	Overload	> 105%
	Transfer Time(UPS Mode)	< 20 ms.
Battery	Type/Voltage	80Ah-200Ah - Tubular, Flat, SMF or Local Battery / 12V
	Number	1
	Typical Recharge Time	10-12 Hrs.
	Protection	Low Battery, Reverse Polarity
Physical	Net weight (Kg.)	10.3
	Gross weight (Kg.)	11.3
	Dimension (LxWxH) mm	355X275X140
LED Displays	Power Switch ON (ECO/UPS Mode)	ECO / UPS LED Indication (As per mode selection)
	Turbo	TURBO indication LED OFF/ON (As per mode selection on battery mode only)
	Low Battery Pre-Alarm	LOW BATTERY LED will blink along with indication LED for ECO / UPS Mode depending upon mode of selection
	Low Battery (B/L)	LOW BATTERY + ECO / UPS (As per mode selection) Indication Steady
	ON Mains	ON MAINS + ECO / UPS (As per mode selection) Indication Steady
	Charging ON (CHG.)	ON MAINS + CHARGING + ECO / UPS (As per mode selection) Indication Steady
	Overload (O/L)	OVERLOAD + ECO / UPS (As per mode selection) Indication Steady
	DC Over Voltage	Battery Low + ECO / UPS Blinking
	Over Temperature	All LED Blinking
	Mains Fuse Failure	Mains LED blinking + ECO / UPS (As per mode selection)
Alarms	Mains to UPS change over	Single Beep for 1 Seconds
	Low Battery Pre-alarm	Beep with 1 second gap till Battery Low
	Low Battery	Continuous beep for 10 Seconds
	Overload & Short circuit	Continuous beep for 10 Seconds
	Overload Pre-alarm	Beep with 1 second gap till Overload
	Over temperature	Continuous beep till fault get reset
	Input Fuse Failure	Continuous beep till fault get reset
Environmental	Operating Temperature	0-45°C (32-113°F)
	Storage Temperature	0-45°C (32-113°F)
	Humidity	0-95% RH non-condensing

Due to continuous product improvement, the specifications are subject to change without notice.